

# TABLE OF CONTENTS

<b>Engineering Information</b>	
Wormgear Style cutaway view . . . . .	4
Bevel Gear Style cutaway view . . . . .	5
Quick Reference Guide . . . . .	6
Options Overview . . . . .	7
Selection Guide Worksheets . . . . .	8
Product Selection Factors . . . . .	10
Column Load . . . . .	11
Jack Designs . . . . .	12
Torque and Horsepower . . . . .	13
Options and Controls . . . . .	14
FAQ . . . . .	16
<b>Machine Screw Jacks</b> . . . . .	18
Ordering Information . . . . .	20
<b>Machine Screw ComDRIVES®</b> . . . . .	45
Ordering Information . . . . .	46
<b>Stainless Steel Screw Jacks</b> . . . . .	58
Ordering Information . . . . .	60
<b>Metric Screw Jacks</b> . . . . .	71
Ordering Information . . . . .	72
<b>Ball Screw Jacks</b> . . . . .	80
Ordering Information . . . . .	82
<b>Ball Screw ComDRIVES®</b> . . . . .	102
Ordering Information . . . . .	104
<b>Electric Cylinders</b> . . . . .	118
Ordering Information . . . . .	120
<b>Integrated Actuators</b> . . . . .	135
Ordering Information . . . . .	137
<b>Linear Actuators</b> . . . . .	143
Ordering Information . . . . .	144
<b>Bevel Gear Jacks</b> . . . . .	148
Ordering Information . . . . .	150
<b>Bevel Ball Actuators</b> . . . . .	159
Ordering Information . . . . .	160
<b>Options, Accessories &amp; Controls</b> . . . . .	168
Protective Boots . . . . .	170
Trunnion Mounts . . . . .	173
Limit Switches . . . . .	174
Potentiometers . . . . .	176
Hand Wheels and Counters . . . . .	177
Encoders . . . . .	178
Special Finishes . . . . .	179
Anti-backlash Devices . . . . .	180
Miter Gear Boxes . . . . .	182
Motor Mounts and Stock Motors . . . . .	185
Pillow Blocks and Flange Blocks . . . . .	186
Couplings . . . . .	188
Shafting . . . . .	190
Motor Starter Controls . . . . .	192
VSPS Controls . . . . .	193
Linear Actuator Controls . . . . .	194
System Arrangements . . . . .	195

ENGINEERING INFORMATION
MACHINE SCREW JACKS
MACHINE SCREW ComDRIVES®
STAINLESS STEEL SCREW JACKS
METRIC SCREW JACKS
BALL SCREW JACKS
BALL SCREW ComDRIVES®
ELECTRIC CYLINDERS
INTEGRATED ACTUATORS
LINEAR ACTUATORS
BEVEL GEAR JACKS
BEVEL BALL ACTUATORS
OPTIONS, ACCESSORIES AND CONTROLS

# WORMGEAR STYLE JACK UPRIGHT TRANSLATING STYLE SHOWN

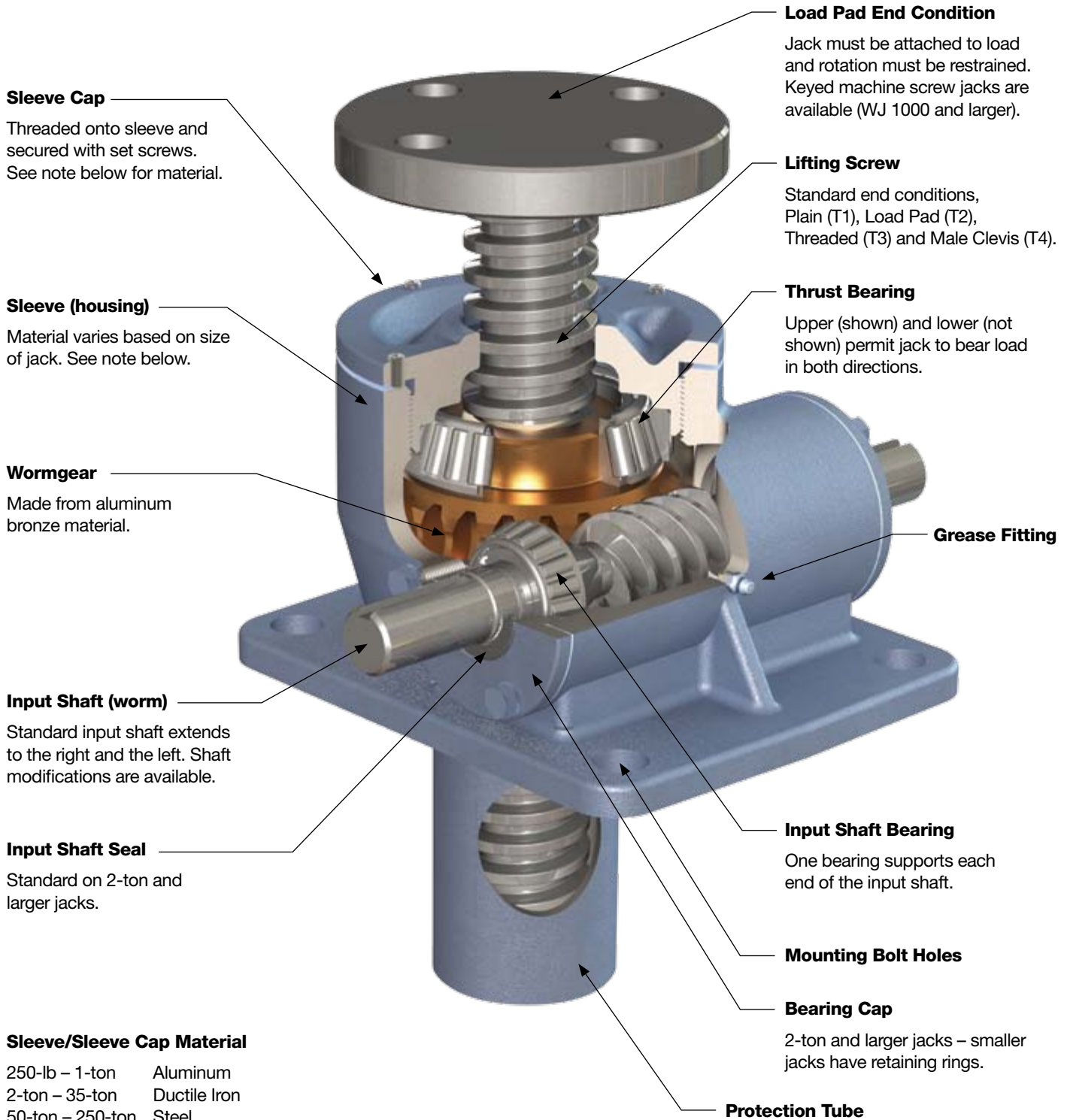

## Sleeve/Sleeve Cap Material

250-lb – 1-ton	Aluminum
2-ton – 35-ton	Ductile Iron
50-ton – 250-ton	Steel

## Options

2-ton	Stainless Steel
5-ton – 25-ton	Stainless Steel
5-ton – 35-ton	Steel

# BEVEL GEAR STYLE JACK UPRIGHT TRANSLATING STYLE SHOWN

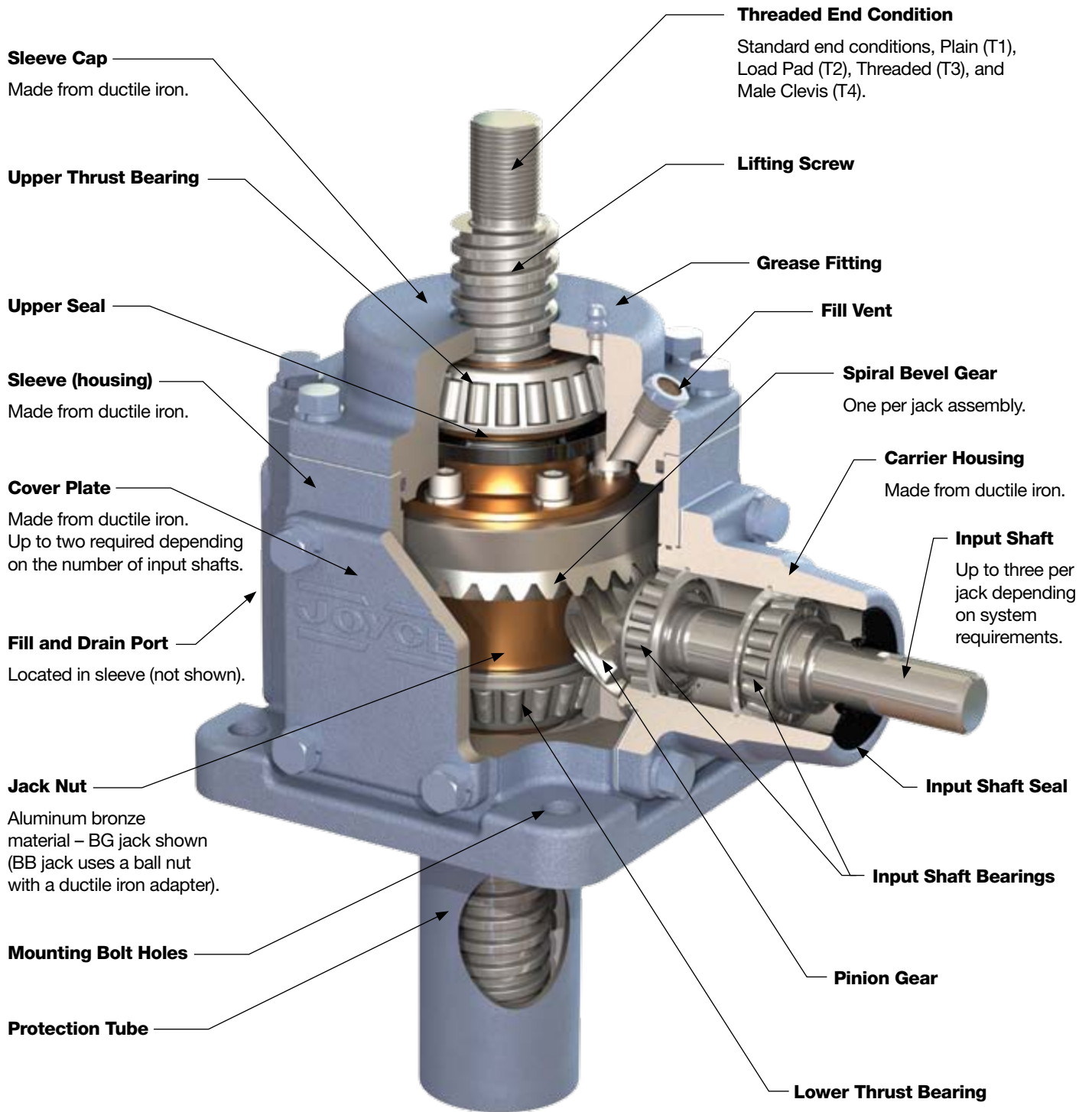

This graphic shows a Joyce Bevel Gear® jack (BG). Bevel ball actuators (BB) also use a bevel gear set. See pages 148 - 167 for more information.

# QUICK REFERENCE GUIDE

Product	Prefix	Capacity Range (tons)	Typical Lifting Speeds (IPM)	Input Shaft		Predictable Life	Inherently Self-Locking	Corrosion Resistant	Enclosed Screw	Options			
				In-line	Right Angle					Keyed for Non-rotation	Limit Switch	Direct Drive Motor Mount	Anti-backlash or Limited End Play
Machine Screw Jack (pp. 18-44)	WJ RWJ DWJ DRWJ	1/8-250	14-55	■			A WJ, RWJ	C		■	■	■	■
Machine Screw ComDRIVE® (pp. 45-57)	CD DCD	2-30	2-35	■			A CD	C		■	■		■
Stainless Steel Jack (pp. 58-70)	SWJ RSWJ DSWJ DRSWJ	2-25	14-55	■			A SWJ, RSWJ	■		■	■	■	■
Metric Jack (pp. 71-79)	MWJ	1-10 (10-100 Kn)	14-55 (6-23 mm/sec)	■			■	C		■	■	■	■
Ball Screw Jack (pp. 80-101)	WBL HWBL WB HWB	1-50	14-300	■		■ Screw Only		C			■	■	D
Ball Screw ComDRIVE® (pp. 102-117)	CDB CDBL	2-30	2-55	■		■ Screw Only		C			■		D
Electric Cylinder-Standard (pp. 118-134)	ECA ECB	2 1/2-20	15-540	■		■ ECB Screw Only	B ECA	C	■		■		D
Electric Cylinder - Motor Mount (pp. 118-134)	ECA ECB	2 1/2-20	18-540	■		■ ECB Screw Only	B ECA	C	■		■	■	D
Electric Cylinder - ComDRIVE® (pp. 118-134)	ECA ECB	2 1/2-20	15-104	■		■ ECB Screw Only	B ECA	C	■		■		D
Integrated Actuator (pp. 135-142)	IA DIA BIA HBIA	1	15-350	■		■ BIA, HBIA Screw Only	■ IA	C	■		■	■	D
Linear Actuator (pp. 143-147)	LA	3/4	15-70				■		■		■		
Bevel Gear Jack (pp. 148-158)	BG	5-60	50-130	■	■		A Single Lead	C		■	■		
Bevel Ball Actuator (pp. 159-167)	BB	5-60	15-600	■	■	■		C			■		D

**A** Jacks with single lead screws (except WJ500) are self-locking. Double lead screw jacks may lower under load.

**B** ECA jacks that are ≤ 30% efficient are self-locking.

**C** Joyce/Dayton offers a variety of finishes and modifications that resist corrosion. (p. 179)

**D** Oversized ball bearings can be added to limit the end play between the ball screw and ball nut.

# OPTIONS OVERVIEW FOR JACKS AND ACTUATORS



## Protective Boots (pp. 170-172)

- Protection from dirt and dust
- Guard against moisture
- Guard against corrosive contaminants
- Neoprene coated nylon (std)
- Special materials available



## Lubrication

- Standard operating (40°F to 220°F)
- Low temperature option
- High temperature option
- Food grade option



## ComDRIVE® Options (pp. 47 & 105)

- Special reducer ratios available
- Special mounting positions available
- Special motor adapters available
- Mount limit switch to gear reducers



## Mechanical Counters (p. 177)

- 0.001" increments (CNT0)



## Motor Mounts (p. 185)

- Available on 2-ton to 20-ton wormgear jacks and electric cylinders
- Included on integrated actuators
- NEMA motor mounts
- Special mounts available



## Machine Screws

- Right hand thread standard
- Left hand thread available on many models
- Special material available
- Special pitch/lead available
- Special finishes available
- Special machining options
- Special end conditions available



## Hand Wheels (p. 177)

- 4" – 12" dia. (standard)
- Aluminum (standard)
- Stainless steel available



## Screw Stops

- Standard on ComDRIVES
- Adjustable
- Bolt-on

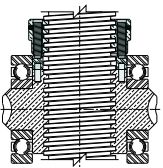

## Anti-backlash Devices (pp. 180-181)

- Available for machine screw jacks
- Available for metric (trapezoidal) jacks
- Limits lifting screw movement



## Ball Screw Options

- Right hand thread standard
- Left hand thread available on many models
- Special pitch/lead available
- Special finishes available
- Special machining options



## Potentiometers (p. 176)

- 0-10V (POTA)
- 4-20mA (POTB)
- 0-10V with limit switches (POTC)
- 4-20mA with limit switches (POTD)
- IP65 available



## Finishes (p. 179)

- Enamel finish (standard)
- Epoxy finish
- Epoxy finish – STEEL IT epoxy
- Outdoor paint process
- Custom finishes available
- Anodized (250-lb to 1-ton)
- Nickel, Xylan®, Armoloy®



## Oversized Ball Bearings

- Available for ball screw jacks
- Limits screw backlash to 0.003"



## Wormgear Sets

- Right hand gear set standard
- Left hand available on many models
- 25:1 ratio option available on several models



## Limit Switches (pp. 174-175)

- Rotary cam (2-7 switches)
- SPDT standard
- DPDT available
- Explosion proof available

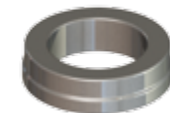

## Thrust Rings

- Used in applications where static loads exceed jack capacity



## Input Shaft (worm)

- Square or hex to fit tool
- Special lengths
- 17-4 stainless steel available
- Metric diameters available
- One side can be cut off
- Other modifications available
- Input shaft cover available



## Encoders (p. 178)

- Standard 200 PPR, quadrature mount on input shaft
- OR
- Ring Style 60 PPR, quadrature mounts to C-faced motor flange

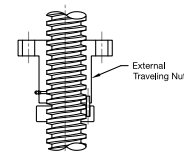

## Follower Nuts (p. 17)

- For KFTN jack
- For translating jack

# SELECTION GUIDE WORKSHEET JACKS AND ACTUATORS

Name \_\_\_\_\_ Title \_\_\_\_\_  
 Company \_\_\_\_\_  
 Address \_\_\_\_\_  
 Phone \_\_\_\_\_ Fax \_\_\_\_\_ Email \_\_\_\_\_

**Jacks To Be Specified – Refer to page 6 for a Quick Reference Guide or contact Joyce/Dayton.**

- |  |   |   |
|--|---|---|
| <input type="checkbox"/> Machine Screw Jacks   | <input type="checkbox"/> Machine Screw ComDRIVES® | <input type="checkbox"/> Electric Cylinders   |
| <input type="checkbox"/> Ball Screw Jacks      | <input type="checkbox"/> Ball Screw ComDRIVES®    | <input type="checkbox"/> Linear Actuators     |
| <input type="checkbox"/> Stainless Steel Jacks | <input type="checkbox"/> Metric Screw Jacks       | <input type="checkbox"/> Integrated Actuators |
| <input type="checkbox"/> Bevel Gear Jacks      | <input type="checkbox"/> Bevel Ball Actuators     |   |

**System Considerations**

Number of jacks \_\_\_\_\_ Total system load \_\_\_\_\_ Load per jack \_\_\_\_\_  
 Jacks are mounted in  Tension  Compression  Both Tension & Compression  
 Jack mounting  Upright  Inverted  
 Screw orientation  Vertical  Horizontal  
 Rise/Stroke \_\_\_\_\_  Inches or  Millimeters  
 Travel Speed \_\_\_\_\_  in/min or  mm/sec  
 Is static side load present?  No  Yes, specify amount \_\_\_\_\_  
 How will jacks be operated?  Electrically – Voltage \_\_\_\_\_ Cycles \_\_\_\_\_ Phase \_\_\_\_\_  Manually  Other

**Environmental and Other Considerations**

Temperature Range \_\_\_\_\_  °F  °C  
 Environment  Dust  Dirt  Oil  Sand  Water  Wash Down  Outdoor  
 Describe any vibration or shock loading: \_\_\_\_\_  
 Duty Cycle  Cycles per minute \_\_\_\_\_  Cycles per hour \_\_\_\_\_  Cycles per day \_\_\_\_\_  
 Describe one complete cycle: \_\_\_\_\_  
 How frequently will the system cycle? \_\_\_\_\_  
 What is the dwell time between cycles? \_\_\_\_\_  
 How will the system lift the load?  Full stroke  Partial stroke  Incrementally  
 How will the system lower the load?  Full stroke  Partial stroke  Incrementally

**Options, Accessories and Controls – Refer to page 7 for an options overview or contact Joyce/Dayton.**

- |   |   |  |   |
|---|---|--|---|
| <input type="checkbox"/> Protective Boots | <input type="checkbox"/> Anti-backlash Device   | <input type="checkbox"/> Motor Mount           | <input type="checkbox"/> Trunnion             |
| <input type="checkbox"/> Limit Switches   | <input type="checkbox"/> Encoder                | <input type="checkbox"/> Ring Encoder          | <input type="checkbox"/> Geared Potentiometer |
| <input type="checkbox"/> Hand Wheel       | <input type="checkbox"/> Mechanical Counter     | <input type="checkbox"/> Shafting              | <input type="checkbox"/> Couplings            |
| <input type="checkbox"/> Miter Gear Box   | <input type="checkbox"/> Gear Reducer           | <input type="checkbox"/> Pillow Block Support  | <input type="checkbox"/> Flange Block Support |
| <input type="checkbox"/> Motor Starter    | <input type="checkbox"/> Synchronizing Controls | <input type="checkbox"/> Programmable Controls | <input type="checkbox"/> Custom Controls      |

**Other Considerations**

Please list in detail any other specific features desired:  
 \_\_\_\_\_  
 \_\_\_\_\_  
 \_\_\_\_\_

**Complete this worksheet and fax or email to Joyce/Dayton.**  
**Please include a sketch or JAX layout of your proposed installation.**  
 JAX software is available as a free download from [www.joycedayton.com](http://www.joycedayton.com).

Joyce/Dayton Corp. • P.O. Box 1630 • Dayton, Ohio 45401  
 800-523-5204 • 937-294-6261 • (Fax) 937-297-7173  
[sales@joycedayton.com](mailto:sales@joycedayton.com)



# SELECTION GUIDE WORKSHEET CONTROLS

Name \_\_\_\_\_ Title \_\_\_\_\_  
Company \_\_\_\_\_  
Address \_\_\_\_\_  
Phone \_\_\_\_\_ Fax \_\_\_\_\_ Email \_\_\_\_\_

## System Information

Number of Jacks \_\_\_\_\_ Number of Motors \_\_\_\_\_  
Are Jacks:  Mechanically Synchronized  Electrically Synchronized  Independently Operated

## System Environment

- Indoor/General Purpose
- Outdoor
- Wash Down
- Hazardous/Outdoor
- Coastal/Salt Spray

## Enclosure Requirement

- NEMA 1
- NEMA 4
- NEMA 4X
- NEMA 12
- Other

## What aspect of operation needs to be controlled?

- Position
- Travel Speed
- Both Position and Travel Speed
- Other (Leveling)

## Motor Requirements

Horsepower \_\_\_\_\_  
Voltage \_\_\_\_\_  
Phase \_\_\_\_\_

Frequency \_\_\_\_\_

Brake required  YES  NO

Brake Voltage \_\_\_\_\_

Brake Wiring  Internal

External (for variable frequency drives)

## Motor Operation

- Variable Speed
- Constant Speed
- Multiple Speed (preset)
- Inch/Jog (stepper)
- Synchronous

## Motor Enclosure

- Totally Enclosed TEFC
- Wash Down
- Explosion Proof

## Primary Control Requirement

- Momentary Operation
- Constant Torque
- Programmable Positions
  - One to Four
  - More than Four
- Accuracy for Positioning  
\_\_\_\_ +/-  inch  mm

- Maintained Operation
- Synchronized Travel  
Tolerance \_\_\_\_ +/-  inch  mm
- Variable Speed  
Range of frequency \_\_\_\_\_
- Soft Start Operation
  - Rate (in/min<sup>2</sup>)
  - Number of starts/hour

## Control Options

- Alarms  Indicators  Pendant Control  Wireless Control  HMI/Touch Screen

## Other Considerations

Please list in detail any other specific features desired:

---

---

---

## Complete this worksheet and fax or email to Joyce/Dayton.

Joyce/Dayton Corp. • P.O. Box 1630 • Dayton, Ohio 45401  
800-523-5204 • 937-294-6261 • (Fax) 937-297-7173  
sales@joycedayton.com



- 1. Maximum Input RPM** – Limited to 1750 RPM for jacks and actuators. Maximum input RPM may be slower than 1750 RPM depending on the dynamic load and other factors specific to the application. Refer to the JAX® selection software and information located in the product section for more detail or contact Joyce/Dayton and talk with an application engineer.
- 2. Side Load** – Standard jacks and actuators are not designed for dynamic side loads. The load must be positioned axially. Static side loads are limited. Contact Joyce/Dayton for technical assistance.
- 3. Duty Cycle** – Relationship between operation time and rest time. The allowable duty cycle for jacks and actuators is based upon several application variables such as load, speed, and temperature. Consideration must be given to the severity of the duty cycle during the product selection phase. Contact Joyce/Dayton and talk with an application engineer about your requirements.
- 4. Self-Locking Jacks** – Screw jacks that require power to raise or lower. Exceptions include WJ500, machine screw jacks having double lead screws and ECA electric cylinders that are more than 30% efficient and all ball screw jacks. A brake must be used on the input shaft of any jack that is not self-locking. A brake should also be included for applications that expose the jack or actuator to vibration. Contact Joyce/Dayton for more information.
- 5. Jacks That Require a Brake Motor** – Any jack that will lower under load requires a brake motor. This includes ball screw jacks (WB, HWB, WBL, HWBL), ball screw ComDRIVES® (CDB, CDBL, CDHB, CDHBL), ball screw electric cylinders (ECB), ball screw integrated actuators (BIA, HBIA), and bevel ball actuators (BB). Machine screw jacks with double lead screws and WJ500 jacks may also require brakes to hold position.
- 6. Travel Speed Limitations** – Typical travel speeds for various jacks and actuators are measured in inches per minute (IPM). Speeds depend on the input RPM, load, internal ratio and lead of the screw. Maximum allowable travel speeds for machine screw jacks are typically slower than ball screw jacks. Wormgear jacks typically have slower travel speeds than bevel gear jacks. Refer to the JAX selection software for more detail or contact Joyce/Dayton and talk with an application engineer.
- 7. Maximum Screw Length** – Maximum distance from the base of the jack to the end of the extended screw. It is limited by the column load in compression. Refer to column load charts or use the JAX selection software. Contact Joyce/Dayton with questions.
- 8. Calculated Life for Machine Screws** – There is no formula available to calculate the life of a machine screw. If a calculated life for the screw is required, specify ball screw jacks, ball screw ComDRIVES®, ball screw electric cylinders, ball screw integrated actuators, or bevel ball actuators. Contact Joyce/Dayton for more information.
- 9. Calculated Life for Ball Screws** – The calculated life for ball screws is based on the ball nut life. This information is available for all ball screw jacks, ball screw ComDRIVES®, ball screw integrated actuators, bevel ball actuators, and ball screw electric cylinders (ECB). It can be obtained using JAX software available as a free download from our website, or by contacting Joyce/Dayton with your requirements.
- 10. Screw Stops** – Stops are offered as options for screw jacks and actuators, and are not to be used as operating limits. Engaging the stop may prevent damage to your structure but will most likely damage the jack. To control jack or actuator travel, include travel limits in the system design. Stops may increase the closed height of the jack and the length of the protection tube. Refer to specific ordering sections in the catalog or contact Joyce/Dayton for more information.  
Note: Screw stops are standard on all Joyce ComDRIVE® jacks.
- 11. Hard Stops** – Jacks are not designed to operate into a hard stop. Sudden impacts and shock loads may cause damage to jacks and actuators. Customers are responsible for providing travel limits to avoid this situation. Contact Joyce/Dayton for more information.
- 12. Standard Operating Temperature** – The standard operating temperature range for most products is 40°F – 220°F. There are some exceptions. For operation outside this range, special lubricants and seals can be provided. Please contact Joyce/Dayton for more information.
- 13. Lubrication of Wormgear Jacks** – Standard wormgear jacks are lubricated with NLGI grade #1 grease prior to shipment. Specific information and commercial brand names can be found in the Operation & Maintenance Manuals, which are available at [www.joycedayton.com](http://www.joycedayton.com).
- 14. Lubrication of Bevel Gear Jacks** – Bevel Gear jacks use both NLGI grade #1 grease and oil. The upper bearing and jackscrew are grease lubricated while the remaining internal components are oil lubricated. These jacks are grease lubricated prior to shipment; *however, oil must be added to the unit prior to operation.* Contact Joyce/Dayton for more information.
- 15. Horizontal Mounting** – When jacks are mounted horizontally, Joyce/Dayton recommends that the input shaft (worm) be mounted below the lifting screw and parallel with the horizon. This position provides the most lubrication to the input shaft (worm), and to both worm shaft bearings. The load capacity of the jack may be reduced when the lifting screw is mounted horizontally. Bevel gear jacks should not be mounted horizontally. Please contact a Joyce/Dayton application engineer to discuss horizontal applications.
- 16. High Screw RPM and Long Screw Lengths** – Keyed for traveling nut (KFTN) jacks with long screw lengths require additional support when the screw rotates at high RPM. Contact a Joyce/Dayton application engineer to discuss applications that require high screw RPM and long screw lengths.

## Column Loading Capacity

The type of load on a jack, and the way the jack is mounted, affects its load bearing capacity. There are two types of possible jack loads, tension and compression. A jack is under tension when its load pulls the screw away from the jack. It is under compression when the load pushes the lifting screw toward the jack (see diagrams). A jack can be under tension or compression regardless of jack positioning (i.e., vertical, horizontal, upright, or inverted).

When tension loaded, the jack retains full rated capacity. Under compression loads, the screw may not be able to support full capacity. For example, a 2-ton jack with a 15" screw length will be limited to 2293 pounds in compression, about half the jack's capacity. In compression the load, screw length and jack mounting configuration determine the load capacity of the screw. The examples shown illustrate four common mounting configurations.

### Unguided

If the screw is the only support for the load, it is considered unguided. The screw must be large enough to support the load and prevent buckling. On the Column Loading charts, use the row labeled "unguided" for the allowable lengths for this design. The Column Loading charts are located within the appropriate product sections of the catalog.

### Trunnion Mounting

In a trunnion mounting arrangement, the screw has a pivot on the end and the jack body is mounted on a large pivoting frame, or trunnion. This type of mounting is particularly common in the antenna industry. In practice, the pivot should be as close to the centerline of the internal nut as design permits. This will eliminate moment loads caused by loose threads. Use the "trunnion" row on the Column Loading charts found within the appropriate product sections of the catalog.

### Guided

Guided loading is often termed "fixed-fixed" loading. With guided loading, both ends of the column are rigidly held – the jack body is bolted firmly to a sturdy base, and the load travels on slides, bearings, rollers or other means. The guides should be snug enough to prevent any side load or moment load from reaching the screw. Use the "guided" row on the appropriate Column Loading charts.

### Double-Clevis Mounting

Double-clevis jacks have less load capacity than the other common mounting configurations. A double-clevis jack has pivots or clevises at both ends: one on the screw tip and one on the end of the protection tube. This tends to weaken it as a column by creating eccentric loads on the screw. This eccentricity tends to increase with greater distance and higher loading. For this reason, double-clevis jacks are limited both in

capacity and maximum length. Double-clevis mounting differs from trunnion mounting because the pivot is located farther from the jack body. The Column Loading charts do not apply for this mounting. Please consult Joyce/Dayton for load bearing information.

### How to use the Column Loading charts:

Note: Charts for machine screw jacks, machine screw ComDRIVES®, metric screw jacks, ball screw jacks, ball screw ComDRIVES®, stainless steel jacks, bevel gear jacks, and bevel ball actuators are located within the specific product section of the catalog. These charts only apply to jacks with axial loads. *For side loads, offset loads, and horizontal mounting, contact Joyce/Dayton.*

1. Determine the type of jack you wish to use and locate that column load chart which is found near the beginning of each product section.
2. Determine the proper mounting arrangement for your application. Locate the appropriate row and find the screw length at the bottom of the chart.
3. Find the load you need to move (in pounds or kilonewtons) on the left side of the chart.
4. Find the point on the chart where the load and length intersect. Choose a jack whose line is on or above this intersection.
5. Add the length of the end condition you have chosen and any additional screw extension to the screw length to find the "unbraced" screw length. Verify your selection using the unbraced length.

### Example:

A jack must lift 5 tons (10,000 pounds) over a distance of 31 inches. The load places the screw in compression. The jack is mounted firmly by its base, and the load is attached to a load pad (Type 2 end) and is not guided.

1. In this example, a machine screw jack will be used so locate the Column Loading chart for machine screw jacks on page 24.
2. Look at the "unguided" row at the bottom of the machine screw jack Column Loading chart and find the 31" mark.
3. From this, the 10-ton double lead jack is selected. Look at the dimensions from the jack body for the Type 2 end for this jack. The Type 2 end adds 2" from the top of the jack to the end of the screw. Thus the total unbraced length of the screw is 31" + 2" = 33".
4. Use this new unbraced screw length to verify your selection. In this case, the intersection point still falls below the 10-ton double lead jack line, so this selection is correct.

### Compression

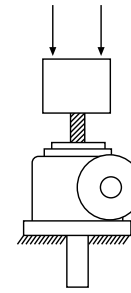

### Tension

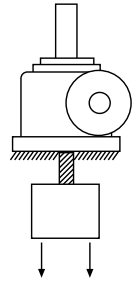

### Unguided

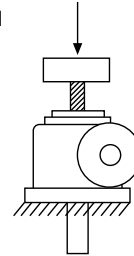

### Trunnion Mount

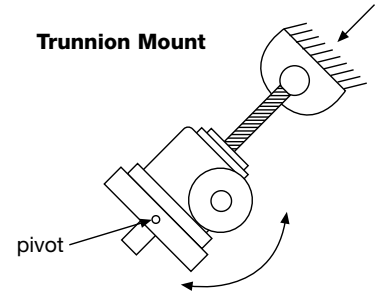

### Guided

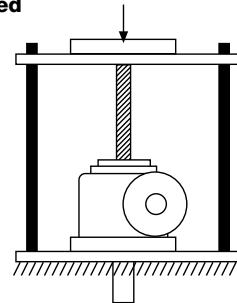

### Double-Clevis

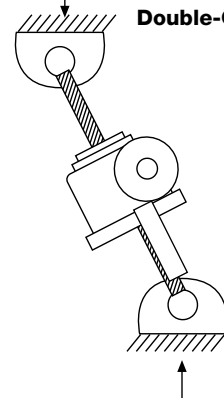

## Joyce Translating Design Jacks

A driven worm acts on an internal wormgear, which in turn drives a lifting screw to extend or retract. As the lifting screw translates through the body of the jack, inherent screw rotation is prevented by an attached load or mounting structure that is anchored to resist rotation.

This design is available for:

- Machine Screw Jacks
- Machine Screw ComDRIVES®
- Stainless Steel Jacks
- Metric Screw Jacks
- Ball Screw Jacks
- Ball Screw ComDRIVES®
- Bevel Gear Jacks
- Bevel Ball Actuators

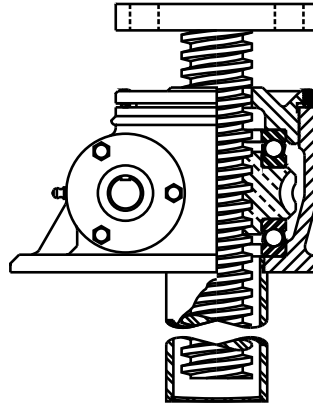

## Joyce Keyed Design Jacks

Some loads do not prevent lifting screw rotation. These applications require a keyed jack. A key, fixed to the jack housing and inserted into a keyway milled into the lifting screw, forces the lifting screw to translate without rotating. Several dimensions of the keyed jack differ from the translating jack – check the keyed jack drawings for each jack model.

This design is available for:

- Machine Screw Jacks (except WJ250 and WJ500)
- Machine Screw ComDRIVES®
- Stainless Steel Jacks
- Metric Screw Jacks
- Bevel Gear Jacks

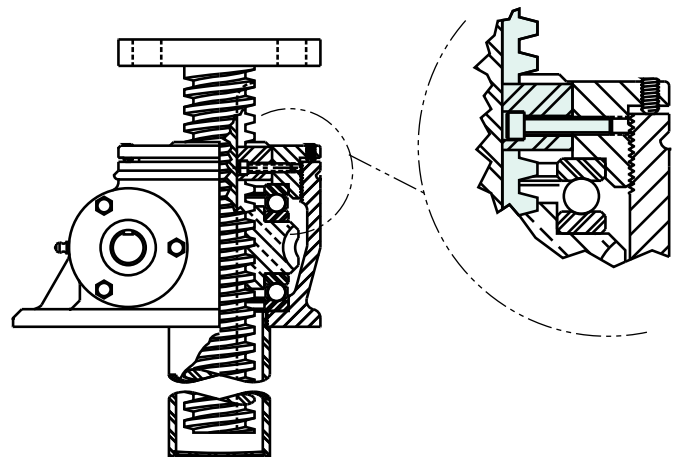

## Joyce Keyed for Traveling Nut (KFTN) Jacks

A keyed for traveling nut jack (sometimes referred to as a rotating screw jack) features a lifting screw keyed to the wormgear as a single unit, forcing the lifting screw to rotate, but not translate. A flanged traveling nut, attached to the load, is driven by the rotation of the lifting screw. This type of jack is ideal for applications that cannot accommodate a screw protection tube or that require a flush mount. Refer to the keyed for traveling nut (KFTN) dimensional drawings for each jack model.

This design is available for:

- Machine Screw Jacks
- Machine Screw ComDRIVES®
- Stainless Steel Jacks
- Metric Screw Jacks
- Ball Screw Jacks
- Ball Screw ComDRIVES®
- Integrated Actuators
- Bevel Gear Jacks
- Bevel Ball Actuators

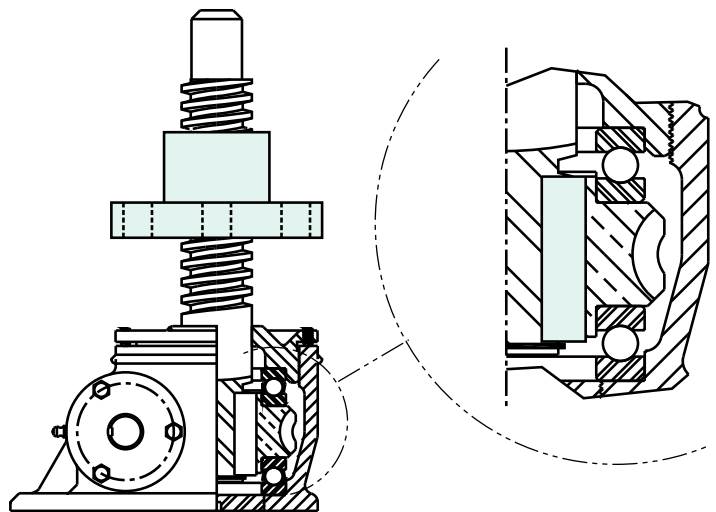

Operating Torque Constants and Tare Torque values can be found on specification pages.

Use the following formula to calculate horsepower:

$$(RPM \times Load \text{ (lb)} \times \text{Operating Torque Constant} + \text{Tare Torque}) / 63025 = \text{Horsepower}$$

### Example 1 – Calculate the horsepower needed to move a load on a single jack (WJT242).

WJT242 has a torque constant of 0.009W with (W) representing the load in pounds and a tare torque of 4 inch-pounds (page 22). Using 350 RPM on the input shaft and a 2000-pound load results in the following horsepower equation:  $(350 \text{ RPM} \times 2000 \text{ lb} \times 0.009 + 4 \text{ in. lbs}) / 63,025 = 0.10 \text{ HP}$

Note: Unlike bevel gear jacks and bevel ball actuators, wormgear style jack input torque requirements vary with input speed, therefore the constants listed in the catalog are only accurate for the RPM listed. To calculate horsepower at speeds other than those listed, please refer to the free JAX® Software or fill out a selection guide (page 8) and contact Joyce/Dayton.

### Example 2 – Calculate the horsepower needed to move a system load (WJT125).

Find the horsepower required to raise a system load of 28,000-pounds, a distance of 10 inches, at a speed of 11 in./min., using four WJT125 jacks (page 22). The load per jack is 7000 pounds.

- Determine input speed:  
32 turns of the input shaft = 1 inch of linear travel.  
 $(32 \text{ turns/inch} \times 11 \text{ inches/min} = 352 \text{ RPM input})$
- Determine the input operating torque plus tare torque for one jack:  
 $(0.025 \text{ in. lbs.} \times 7,000) + 10 \text{ in. lbs} = 185 \text{ in. lbs}$
- Determine the input horsepower for one jack:  
 $(352 \text{ rpm} \times 185 \text{ in. lbs}) / 63,025 = 1.03 \text{ HP per jack}$

To calculate the horsepower required when operating a jack system, it is usually easiest to separate the system into sections. For example, the “H” system can be viewed as two jack systems joined by a speed reducer in the center.

Always remember to take into account the inefficiencies of miter boxes and gear reducers when calculating system horsepower requirements. (For this exercise use 90% efficiency for miter boxes and gear reducers, but in actual systems efficiencies may differ.)

- Determine horsepower required for Section 1:  
Total horsepower required for the left side of the system =  $1.03 \text{ HP per jack} \times 2 \text{ jacks} = 2.06 \text{ HP}$

$2.06 \text{ HP} / .9 = 2.29 \text{ HP}$  required into miter box of Section 1.  
Since Sections 1 and 2 are identical, Section 2 also requires 2.29 HP.

- Determine horsepower required for Sections 1 and 2:  
 $2.29 \text{ HP} + 2.29 \text{ HP} = 4.58 \text{ HP}$

Account for the inefficiency of the central gear reducer to determine the total system horsepower requirement.

$4.58 \text{ HP} / 0.9 = 5.08 \text{ HP}$  required to operate this system

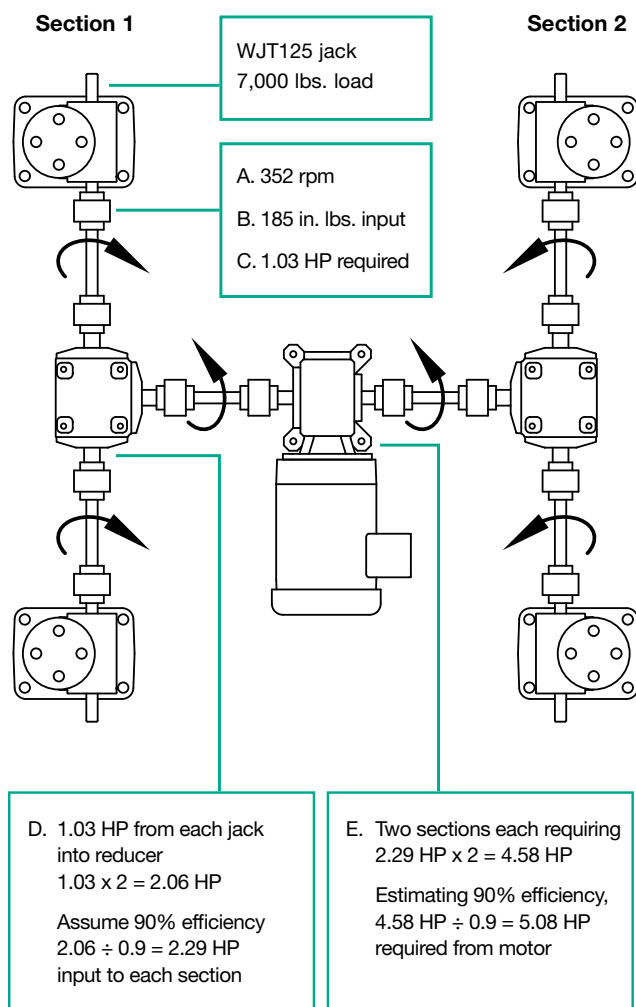

## SHAFT MOUNTED OPTIONS

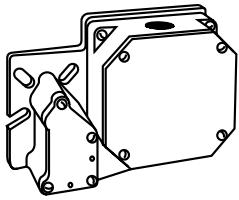

### Rotary Cam Limit Switches

See pages 174-175

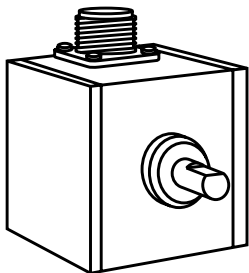

### Encoders 200 PPR Standard

See page 178

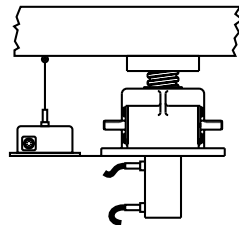

### String Encoder and other Linear Displacement devices

Contact Joyce/Dayton

### Proximity Switches

Contact Joyce/Dayton

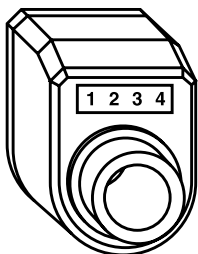

### Mechanical Counters

See page 177

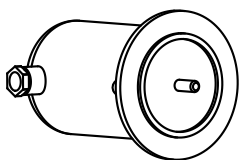

### Geared Potentiometer 0-10V or 4-20Ma

See page 176

Joyce jacks and actuators are at the heart of linear motion systems in thousands of applications worldwide.

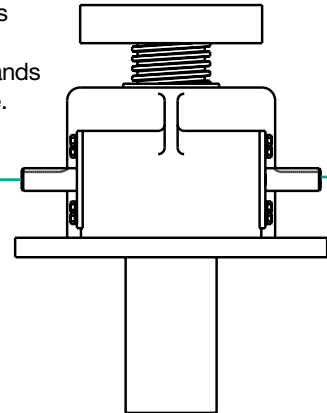

## ACCESSORIES

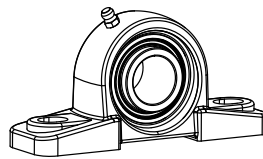

### Pillow Block and Flange Block Supports

See pages 186-187

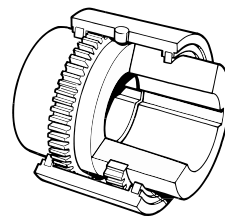

### Shafts and Couplings

See pages 188-191

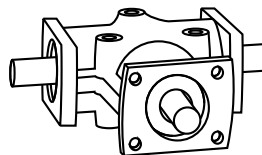

### Miter Gear Boxes

See pages 182-184

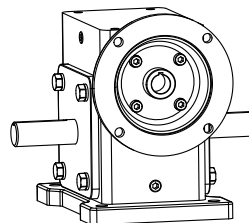

### Speed Reducers

Contact Joyce/Dayton

### DRIVE OPTIONS

#### Hand Wheels

See page 177

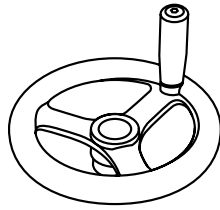

#### Specialty Motors

- AC/DC
- Air
- IEC Frame
- Gear Motor
- International Voltages
- Single Phase
- Brake Motors

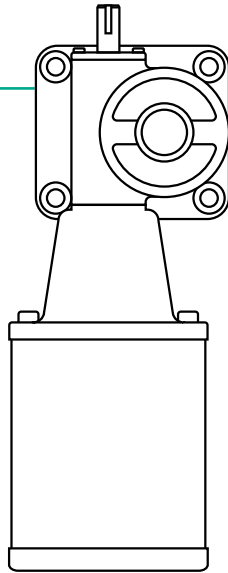

#### Direct Drives

- Stock AC Motor Mounts  
See page 185
- Special Adapters  
Contact Joyce/Dayton
- Ring Encoders  
Contact Joyce/Dayton

#### ComDRIVE®

**Self-contained actuators combine jack, gear reducer and motor in a single compact unit.**

- Machine Screw ComDRIVE®  
See pages 45-57
- Ball Screw ComDRIVE®  
See pages 102-117
- Electric Cylinder ComDRIVE®  
See pages 118-134

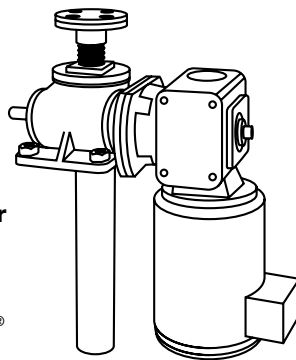

### MOTOR CONTROLS

#### Variable Speed Positioning System (VSPS)

- 10 Programmable Preset positions  
See page 193

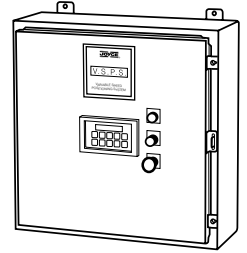

#### Custom Controls include Synchronized Systems, Positioning Systems, and Leveling Systems

- See the back cover of catalog

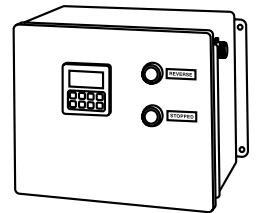

#### Motor Starters

- Momentary Contact Motor Starters  
See page 192

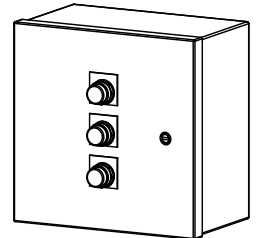

#### Actuator Controls

- 120 VAC - 120 VAC
- 120 VAC - 12 VDC
- 12 VDC - 12 VDC  
See page 194

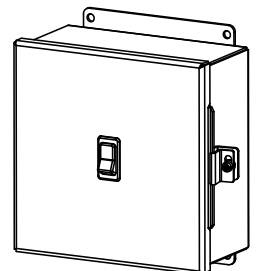

## 1. What is the difference between upright and inverted jack configurations?

The difference between an upright and an inverted jack is the location at which the lifting screw exits the jack relative to the jack base. For example, an upright jack's lifting screw exits the jack opposite the base. An inverted jack's lifting screw exits the jack on the same side as the base. The choice between inverted and upright jack is dependent upon the application.

Note: An upright jack mounted upside down is still referred to as an upright jack.

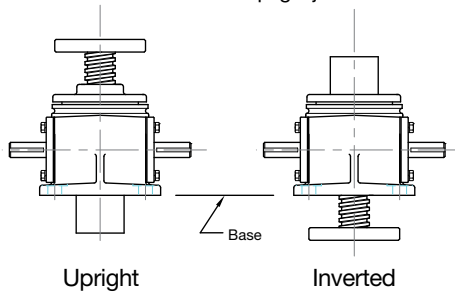

## 2. How can I determine worm shaft rotation extending the lifting screw?

Refer to the views of the standard jack with right hand screw threads below:

- For an Upright jack:  
CCW rotation of right input shaft extends the lifting screw.  
CW rotation of the left shaft extends lifting screw.
- For an Inverted jack:  
CW rotation of right input shaft extends lifting screw.  
CCW rotation of the left shaft extends lifting screw.

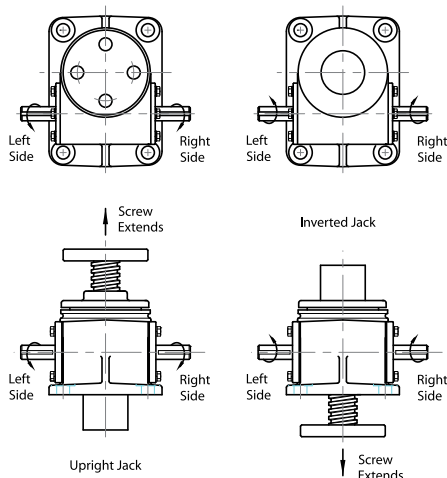

## 3. How is the linear travel speed calculated?

Each screw jack and actuator has an inherent number of input shaft turns per inch (TPI) of screw travel. TPI is the result of the jack's gear ratio divided by the lifting screw lead. The TPI can be found on jack specification pages at the beginning of many product sections. A model WJT242 has a TPI of 96. If 350 RPM is applied to the input shaft, the resultant linear speed of travel is  $350/96$  or 3.65 inches per minute.

## 4. Are screw jacks lubricated prior to shipment?

All Joyce machine screw jacks and ComDRIVES®, ball screw jacks and ComDRIVES®, bevel ball actuators, integrated actuators, and electric cylinders are lubricated with an extreme pressure NLGI grade #1 grease before leaving the factory.

Bevel gear jacks are lubricated with NLGI grade #1 grease and oil. The upper bearing and jackscrew are grease lubricated while the remaining internal components are oil lubricated. They are grease lubricated prior to shipment; however oil must be added to the unit prior to operation.

Linear actuators (LA) are lubricated for life.

## 5. What are the standard end conditions for screw jack lifting screws?

The following standard end conditions are available on Joyce/Dayton screw jacks:

- Type 1  
plain turned end
- Type 2  
load pad with mounting holes
- Type 3  
male threaded end
- Type 4  
male clevis end



Contact Joyce/Dayton for information about custom end conditions.

## 6. How is the clevis, T4 end, positioned on a keyed jack?

- Standard clevis mounting position – the hole in the clevis end is parallel with the worm input shaft.
- Optional mounting position – the hole in the clevis end is perpendicular to the worm input shaft.

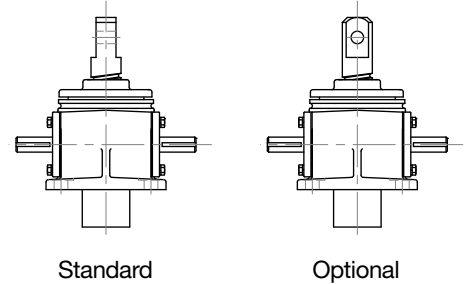

## 7. How is the load pad, T2 end, positioned on keyed jacks?

- Standard load pad mounting position – the holes on the load pad are on the jack centerlines.
- Optional load pad mounting position – the holes on the load pad end straddle the jack centerlines.

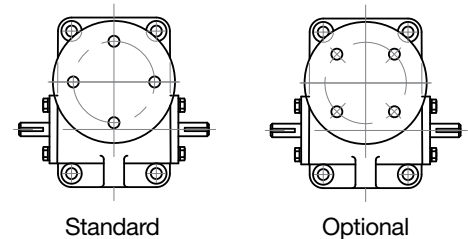

**8. Can I buy a jack with a clevis on both ends?** Yes. When freedom of movement in two axes is required, a double clevis jack may be specified.

- Double clevis jacks incorporate a clevis machined or pinned on the screw end and also a clevis welded to the protection tube.

Screw travel is limited. Contact Joyce/Dayton for more information.

- Electric cylinders, integrated actuators, and linear actuators are also available with a clevis on both ends.

**9. What is meant by “self-locking”?**

Self-locking is a term used to describe jacks that require power to move in either direction. They hold their position when power to the system is off. See page 10 for more details.

**10. What if the jack is not self-locking?**

A brake is required on the input shaft of any jack that may lower under load (ball screw jacks, WJ500 jacks, double-lead Acme screw jacks, integrated actuators, and electric cylinders that are more than 30% efficient). See page 10 for more details.

**11. How much side load can be placed on a screw jack?**

Standard jacks and actuators are not designed for dynamic side loads. The load must be positioned axially. Static side loads are limited. Contact Joyce/Dayton for technical assistance. See page 10 for more details.

**12. How much backlash is in a machine screw jack?**

In machine screw jacks there are two types of backlash: worm to wormgear backlash (typically 8-15° worm rotation), and lifting screw to nut backlash, sometimes called endplay (up to 0.020 inches on new standard jacks). Refer to the JAX® program or contact Joyce/Dayton for more information.

**13. Can I reduce machine screw backlash?**

Yes, screw backlash can be adjusted on translating and keyed style machine screw jacks via one of the following anti-backlash options: standard split-nut design; A90 external nut adjustment; or A95 design. Refer to catalog pages 180-181 or contact Joyce/Dayton for more information.

**14. What is screw lead error?** The deviation from the mathematical lead expressed in inches per foot cumulative.

**15. What is the amount of lead error in a standard lifting screw?** Rolled Acme screws have up to .010 in/ft cumulative error, milled Acme screws have up to 0.003 in/ft cumulative error; and ball screws have up to 0.007 in/ft cumulative error. Contact Joyce/Dayton for more information.

**16. Are Joyce/Dayton jacks and actuators user-serviceable?**

The level to which products can be serviced in the field varies from product to product. Refer to the product Operation & Maintenance Manuals or contact Joyce/Dayton for more information.

**17. What motor options are available?**

Motor options vary among product lines. Customers can use AC 3-phase, AC single-phase, DC motors, international voltage motors and others. Let us know your requirements.

The motors on linear actuators are an integral component. They are available in 120 VAC, or 12 VDC.

**18. What is the clutch on a linear actuator and how is it used?**

A screw clutch device is an option on linear actuators (if they do not have limit switches). This device allows the screw to turn if the actuator is operated against a hard stop. This is an emergency protection device, not to be used repeatedly as an end of travel stop.

**19. Are limit switches preset?** No.

- Shaft-mounted rotary cam limit switches must be set to the required positions during installation.
- Limit switches on linear actuators must be set after the actuators have been installed in order to tailor the stop position to the individual application.

**20. What do I need to consider when ordering a bellows boot to protect the lifting screw?**

- Closed height dimensions may increase when boots are added.
- The customer must specify boot collar diameter when ordering bellows boots for KFTN jacks.
- Zippered boots are also available.
- Special boot material is available.
- Horizontal screw applications may require boot guides.

Contact Joyce/Dayton for more information.

**21. Are jacks and actuators corrosion-resistant?**

Stainless steel jacks are inherently corrosion resistant. All exposed surfaces are stainless steel and aluminum bronze. Most other jacks can be modified with special finishes, coatings, and seals. Contact Joyce/Dayton with your requirements. See page 179.

**22. What is a follower nut assembly and when is it helpful to have one?**

Follower nut assemblies allow customers to gauge the wear on the wormgear screw thread of translating jacks and on the traveling nut screw thread of KFTN jacks. This allows customers to replace the nut before its threads wear too thin to support the design load. These assemblies generally consist of a gear nut or traveling nut pinned to a second nut of dissimilar material. A preset gap separates the two nuts. As the wormgear or traveling nut threads wear, the preset gap narrows. The assembly is replaced when the gap measurement reaches the design limit. Follower nut assemblies are designed for specific applications. Contact Joyce/Dayton for more information.

